



OWNER'S MANUAL

JWBS-16 Woodworking Bandsaw



(shown with optional accessory rip fence, rails and resaw attachment 708747 and miter gauge 708716)

JET
WMH Tool Group
www.wmhtoolgroup.com

P.O. BOX 1349
Auburn, WA 98071-1349
e-mail jet@wmhtoolgroup.com

Phone: 253-351-6000
Fax: 1-800-274-6840
M-708749 04/02

This manual has been prepared for the owner and operators of a JET JWBS-16. Its purpose, aside from machine operation, is to promote safety through the use of accepted correct operating and maintenance procedures. Completely read the safety and maintenance instructions before operating or servicing the machine. To obtain maximum life and efficiency from your JET Bandsaw, and to aid in using the machine safely, read this manual thoroughly and follow instructions carefully.

Warranty & Service

The WMH Tool Group warrants every product it sells. If one of our tools needs service or repair, one of our Authorized Repair Stations located throughout the United States can give you quick service.

In most cases, any one of these WMH Tool Group Repair Stations can authorize warranty repair, assist you in obtaining parts, or perform routine maintenance and major repair on your JET, Performax, Wilton, or Powermatic tools.

For the name of an Authorized Repair Station in your area, please call 1-800-274-6848, or visit www.wmhtoolgroup.com

More Information

Remember, the WMH Tool Group is consistently adding new products to the line. For complete, up-to-date product information, check with your local WMH Tool Group distributor, or visit www.wmhtoolgroup.com

WMH Tool Group Warranty

The WMH Tool Group (including Performax, Wilton and Powermatic brands) makes every effort to assure that its products meet high quality and durability standards and warrants to the original retail consumer/purchaser of our products that each product be free from defects in materials and workmanship as follow: 1 YEAR LIMITED WARRANTY ON ALL PRODUCTS UNLESS SPECIFIED OTHERWISE. This Warranty does not apply to defects due directly or indirectly to misuse, abuse, negligence or accidents, normal wear-and-tear, repair or alterations outside our facilities, or to a lack of maintenance.

THE WMH TOOL GROUP LIMITS ALL IMPLIED WARRANTIES TO THE PERIOD SPECIFIED ABOVE, FROM THE DATE THE PRODUCT WAS PURCHASED AT RETAIL. EXCEPT AS STATED HEREIN, ANY IMPLIED WARRANTIES OR MERCHANTABILITY AND FITNESS ARE EXCLUDED. SOME STATES DO NOT ALLOW LIMITATIONS ON HOW LONG THE IMPLIED WARRANTY LASTS, SO THE ABOVE LIMITATION MAY NOT APPLY TO YOU. THE WMH TOOL GROUP SHALL IN NO EVENT BE LIABLE FOR DEATH, INJURIES TO PERSONS OR PROPERTY, OR FOR INCIDENTAL, CONTINGENT, SPECIAL, OR CONSEQUENTIAL DAMAGES ARISING FROM THE USE OF OUR PRODUCTS. SOME STATES DO NOT ALLOW THE EXCLUSION OR LIMITATION OF INCIDENTAL OR CONSEQUENTIAL DAMAGES, SO THE ABOVE LIMITATION OR EXCLUSION MAY NOT APPLY TO YOU.

To take advantage of this warranty, the product or part must be returned for examination, postage prepaid, to an Authorized Repair Station designated by our office. Proof of purchase date and an explanation of the complaint must accompany the merchandise. If our inspection discloses a defect, we will either repair or replace the product, or refund the purchase price if we cannot readily and quickly provide a repair or replacement, if you are willing to accept a refund. We will return repaired product or replacement at JET'S expense, but if it is determined there is no defect, or that the defect resulted from causes not within the scope of JET'S warranty, then the user must bear the cost of storing and returning the product. This warranty gives you specific legal rights; you may also have other rights which vary from state to state.

The WMH Tool Group sells through distributors only. Members of the WMH Tool Group reserve the right to effect at any time, without prior notice, those alterations to parts, fittings, and accessory equipment which they may deem necessary for any reason whatsoever.

WARNING

1. **Read and understand the entire instruction manual before attempting assembly or operation.**
2. **This bandsaw is designed and intended for use by properly trained and experienced personnel only. If you are not familiar with the proper and safe operation of a bandsaw, do not use until proper training and knowledge have been obtained.**
3. Always wear approved safety glasses/face shields while using this machine.
4. Make certain the machine is properly grounded.
5. Before operating the machine, remove tie, rings, watches, other jewelry, and roll up sleeves above the elbow. Remove all loose clothing and confine long hair. Do **not** wear gloves.
6. Keep the floor around the machine clean and free of scrap material, oil and grease.
7. Keep the machine guards in place at all times when the machine is in use. If removed for maintenance purposes, use extreme caution and replace the guards immediately.
8. Do not over reach. Maintain a balanced stance at all times so that you do not fall or lean against blades or other moving parts.
9. Make all machine adjustments or maintenance with the machine unplugged from the power source.
10. Use the right tool. Don't force a tool or attachment to do a job which it was not designed for.
11. Replace warning labels if they become obscured or removed.
12. Make certain the bandsaw power switch is in the off position before connecting the machine to the power supply.
13. Give your work undivided attention. Looking around, carrying on a conversation, and "horse-play" are careless acts that can result in serious injury.
14. Keep visitors a safe distance from the work area.
15. Use recommended accessories; improper accessories may be hazardous.
16. Adjust and position upper and lower blade guides before starting to cut. Upper blade guide should be adjusted to approximately 1/8" above the material to be cut.
17. Adjust blade tension and tracking before starting to cut.
18. Always keep hands and fingers away from the blade when the machine is running.
19. Stop the machine and wait for the blade to stop moving before removing scrap material from the table.
20. Use suitable support if stock does not have a flat surface.
21. Hold material firmly against the table.
22. Saw teeth must point down toward the table.
23. Some dust created by power sanding, sawing, grinding, drilling and other construction activities contains chemicals known to cause cancer, birth defects or other reproductive harm. Some examples of these chemicals are:
 - Lead from lead based paint
 - crystalline silica from bricks and cement and other masonry products, and
 - arsenic and chromium from chemically-treated lumber.
24. Your risk from those exposures varies, depending on how often you do this type of work. To reduce your exposure to these chemicals: work in a well ventilated area, and work with approved safety equipment, such as those dust masks that are specifically designed to filter out microscopic particles.
25. Do not operate tool while under the influence of drugs, alcohol or any medication.
26. **Failure to comply with all of these warnings may cause serious injury.**

Grounding Instructions

Caution: This tool must be grounded while in use to protect the operator from electric shock.

In the event of a malfunction or breakdown, grounding provides a path of least resistance for electric current to reduce the risk of electric shock. This tool is equipped with an electric cord having an equipment-grounding conductor and a grounding plug. The plug must be plugged into a matching outlet that is properly installed and grounded in accordance with all local codes and ordinances.

Do not modify the plug provided. If it will not fit the outlet, have the proper outlet installed by a qualified electrician.

Improper connection of the equipment-grounding conductor can result in a risk of electric shock. The conductor, with insulation having an outer surface that is green with or without yellow stripes, is the equipment-grounding conductor. If repair or replacement of the electric cord or plug is necessary, do not connect the equipment-grounding conductor to a live terminal.

Check with a qualified electrician or service personnel if the grounding instructions are not completely understood, or if in doubt as to whether the tool is properly grounded. Use only three wire extension cords that have three-prong grounding plugs and three-pole receptacles that accept the tool's plug.

Repair or replace a damaged or worn cord immediately.

115 Volt Operation

As received from the factory, your bandsaw is ready to run at 115 volt operation. This bandsaw, when wired for 115 volts, is intended for use on a circuit that has an outlet and a plug that looks the one illustrated in Figure A. A temporary adapter, which looks like the adapter as illustrated in Figure B, may be used to connect this plug to a two-pole receptacle, as shown in Figure B if a properly grounded outlet is not available. The temporary adapter should only be used until a properly grounded outlet can be installed by a qualified electrician. **This adapter is not applicable in Canada.** The green colored rigid ear, lug, or tab, extending from the adapter, must be connected to a permanent ground such as a properly grounded outlet box, as shown in Figure B.

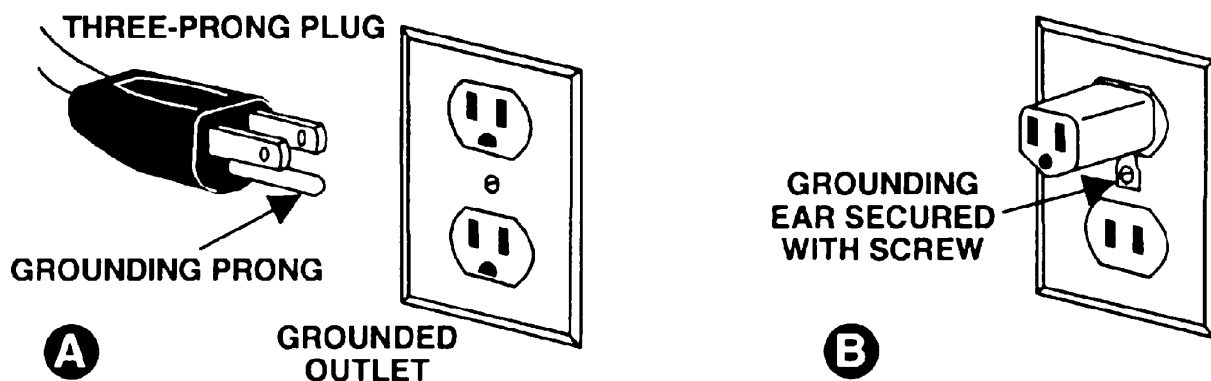

230 Volt Operation

If 230V, single phase operation is desired, the following instructions must be followed:

1. Disconnect the machine from the power source.
2. This bandsaw is supplied with four motor leads that are connected for 115V operation, as shown in Figure A. Reconnect these four motor leads for 230V operation, as shown in Figure B.
3. The 115V attachment plug supplied with the bandsaw must be replaced with a UL/CSA listed plug suitable for 230V operation. Contact your local Authorized JET Service Center or qualified electrician for proper procedures to install the plug. The bandsaw must comply with all local and national codes after the 230V plug is installed.
4. The bandsaw with a 230V plug should only be connected to an outlet having the same configuration. No adapter is available or should be used with the 230V plug.

Important: In all cases (115 or 230 volts), make certain the receptacle in question is properly grounded. If you are not sure, have a registered electrician check the receptacle.

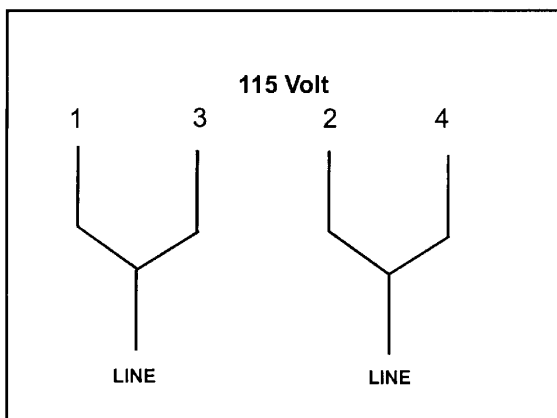

FIGURE A

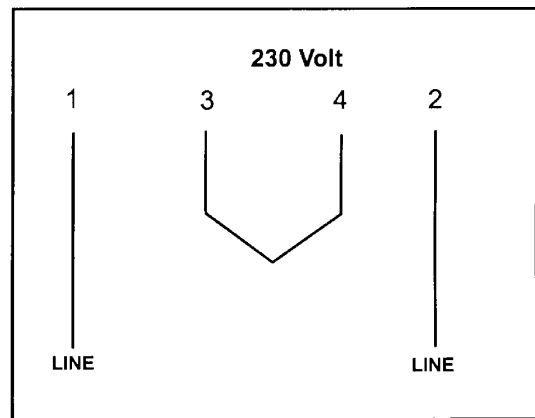

FIGURE B

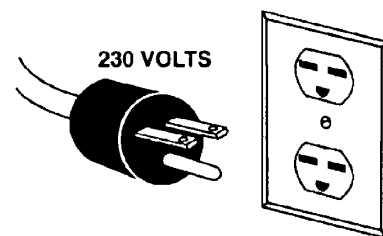
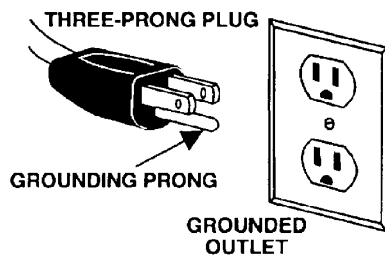

Table of Contents

Warranty	2
Warnings	3
Grounding Instructions	4
115 Volt Operation	4
230 Volt Operation	5
Specifications	6
Contents of Shipping Container	7
Unpacking	7
Tools Included for Assembly	7
Tools Required for Assembly and Adjustments	7
Assembly and Setup	8
Adjusting Blade Tension	8
Adjusting Blade Tracking	8
Upper Blade Guide Adjustment	9
Lower Blade Guide Adjustment	9
Mounting the Table	10
Adjusting 90 Degree Table Stop	10
Rail Assembly	11
Fence Assembly and Adjustment	11-12
Resaw Guide	12
Miter Gauge	12
Tilting the Table	13
Height Scale Adjustment	13
Changing Blades	14
Replacing Belt	15
Adjusting Belt Tension	15
Electrical Connections	16
Maintenance	16
Available Accessories	16
Troubleshooting	17
Part's Breakdowns and Part's List	18-29
Wiring Diagram	30

Specifications:

JWBS-16

Stock Number	708749
Cutting Capacity (height)	10"
Cutting Capacity (width)	16"
Maximum Rip Left of Blade w/Fence	14-1/4"
Blade Length	123"
Blade Speed	3000 SFPM
Minimum Blade Width	1/8"
Maximum Blade Width	1-1/2"
Table Size	17" x 17"
Table Tilt	45°R to 10°L
Table Height from Floor	35"
Wheel Diameter	16-5/8"
Dust Chute Diameter	4"
Overall Dimensions	69" H x 30-1/4" W x 27" D
Motor	1-1/2 HP, 1Ph
.....	115/230V, prewired 115V
Net Weight (approx.)	285 lbs.
Shipping Weight (approx.)	300 lbs.

The specifications in this manual are given as general information and are not binding. The WMH Tool Group reserves the right to effect, at any time and without prior notice, changes or alterations to parts, fittings, and accessory equipment deemed necessary for any reason whatsoever.

Contents of Shipping Container

1. Bandsaw
1. Table
1. Owner's Manual
1. Warranty Card
2. Cast Feet
- 4 Hex Cap Bolts 3/8"-16x4"
- 4 Flat Washers 3/8"
- 4 Lock Washers 3/8"
- 4 Flat Washers 3/8" (plastic)
1. Accessory Package Contains:
 2. Knobs
 1. Hex Wrench
 1. Handle
 1. 10/12mm Wrench

Unpacking

1. Remove the packing material from the bandsaw.
2. Move the saw to its permanent working location. The site should be dry, well lit, and have enough room to handle long stock and the service and/or adjustment of the machine from any side.
3. Have another person help you remove the bandsaw from the box.
4. Clean all rust protected surfaces with a mild solvent or diesel fuel and a soft cloth. Do not use lacquer thinner, paint thinner, or gasoline. These will damage painted surfaces.

Tools Included for Assembly

1. 10/12mm Open End Wrench
1. Hex Wrench

Tools Required for Assembly & Adjustments

2. 14mm Open End Wrench
1. Combination Square
1. Cross Point Screw Driver



(shown with optional accessory rip fence, rails and resaw attachment 708747 and miter gauge 708716)

Assembly and Setup

1. With help from another person tilt the bandsaw just enough to get one set of feet (A, Fig. 1) underneath the base. Line up holes and bolt (B, Fig. 1) through the base into the feet using *two* hex cap bolts 3/8"-16x4", *two* 3/8" lock washers, *two* 3/8" flat washers, and *two* 3/8" plastic flat washers. Repeat for opposite end.
2. Attach the handle (C, Fig. 2) to the handwheel (D, Fig. 2).

Adjusting Blade Tension

1. **Disconnect machine from the power source, unplug.**
 2. Turn blade tension hand wheel (E, Fig. 2) counter-clockwise to tension blade, and clockwise to loosen the tension. A gauge on the upper wheel slide bracket (F, Fig. 2) indicates the approximate tension according to the width of the blade. The JWBS-16 comes with a 3/4" blade so the tension should be set at 3/4" when using this blade.
- As you become familiar with the saw, you may find it necessary to change the blade tension from the initial setting. Changes in blade width, and the type of material being cut will have an effect on blade tension.
 - Keep in mind that too little, or too much blade tension can cause blade breakage and/or poor cutting performance.

Adjusting Blade Tracking

 **WARNING**

**Disconnect machine from the power source!
Never adjust blade tracking with the
machine running!
Failure to comply may cause serious injury!**

Note: Blade tracking has been adjusted at the factory. If, however, it is determined that blade tracking needs adjustment:

1. Blade must be properly tensioned before adjusting blade tracking. Make sure upper and, lower blade guides do not interfere with the blade while adjusting the tracking.
2. Open the upper wheel door. Rotate the wheel forward, and observe the position of the blade on the wheel. The blade should

rest in approximately the center of the wheel.

3. If adjustment is necessary, loosen the wing nut (G, Fig. 2) at the top rear of the saw.
4. Adjust tracking by turning the knob (H, Fig. 2) in 1/4 turn increments. Rotate the wheel forward, and observe the position of the blade on the wheel. Rotating knob (H, Fig. 2) counter-clockwise should move the blade towards the front of the wheel. Rotating the knob clockwise should move the blade towards the back of the wheel.
5. Continue with adjustments until the blade is tracking properly.
6. Tighten the wing nut (G, Fig. 2).

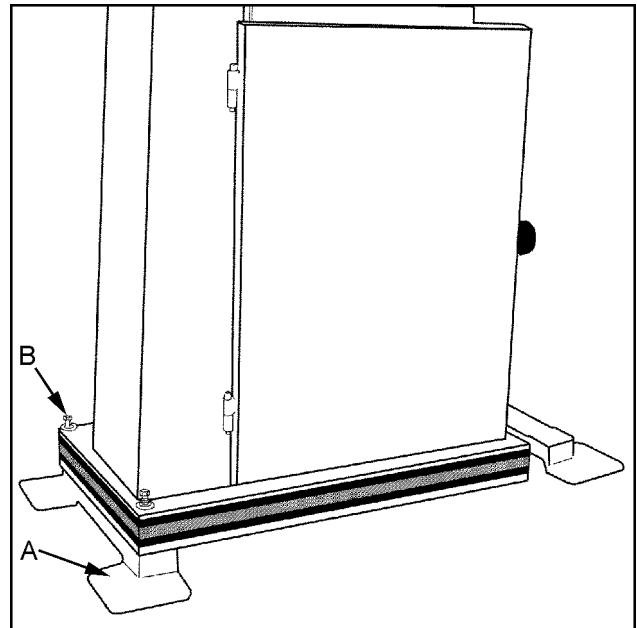

Fig. 1

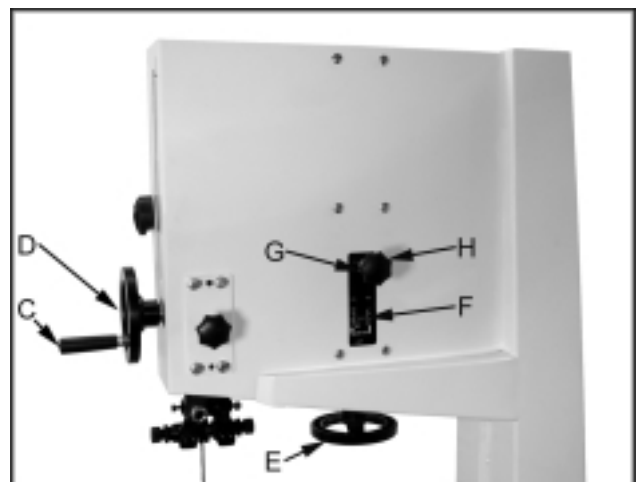

Fig. 2

Upper Blade Guide Adjustment

WARNING

Disconnect machine from the power source, unplug before making any adjustments! Blade teeth are sharp! Use care when working near the saw blade. Failure to comply may cause serious injury!

1. Blade tension and tracking must be properly adjusted prior to blade guide setup.
2. The blade guard has been removed in Figure 3 for photo purposes only.
3. Loosen the socket head cap screw (A, Fig. 3) and position the blade guide assembly (B, Fig. 3) so that the guides rest just behind the gullet of the blade teeth. Tighten the socket head cap screw.
4. Loosen lock nuts (D, Fig. 3).
5. Adjust guide knobs (E, Fig. 3) so guides (C, Fig. 3) rest lightly against the blade. **Do not** force the guides against the side of the blade. Tighten both lock nuts.
6. Adjust the blade support bearing so that it is 0.003" away from the back of the blade, about the thickness of a piece of paper. To make this adjustment loosen thumb screw (F, Fig. 3) and slide the bearing and bearing post into position. Tighten thumb screw.

Note: Blade support bearing should be adjusted so that the back edge of the blade overlaps the front face of the ball bearing by approximately 1/8". If adjustment is needed, loosen thumb screw (F, Fig. 3) and turn the bearing shaft. Tighten thumb screw.

Lower Blade Guide Adjustment

WARNING

Disconnect machine from the power source, unplug before making any adjustments! Blade teeth are sharp! Use care when working near the saw blade. Failure to comply may cause serious injury!

1. Blade tension and tracking must be properly adjusted prior to blade guide setup.
2. The blade guard has been removed in Figure 4 for photo purposes only.

3. Loosen the socket head cap screws (G, Fig. 4) and position the blade guide assembly (H, Fig. 4) so that the guides rest just behind the gullet of the blade teeth. Tighten the socket head cap screws.
4. Loosen thumb screws (I, Fig. 4). Adjust guides (J, Fig. 4) so they rest lightly against the blade. Do not force the guide against the side of the blade. Tighten thumb screws.
5. Adjust the blade support bearing so that it is 0.003" away from the back of the blade, about the thickness of a piece of paper. To make this adjustment loosen thumb screw (K, Fig. 4) and slide the bearing, and bearing post into position. Tighten thumb screw.

Note: Blade support bearing should be adjusted so that the back edge of the blade overlaps the front face of the ball bearing by approximately 1/8". If adjustment is needed loosen thumb screw (K, Fig. 4) and turn the bearing shaft. Tighten thumb screw.

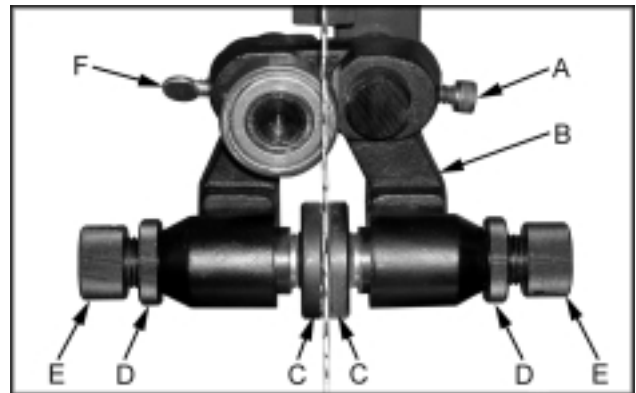

Fig. 3

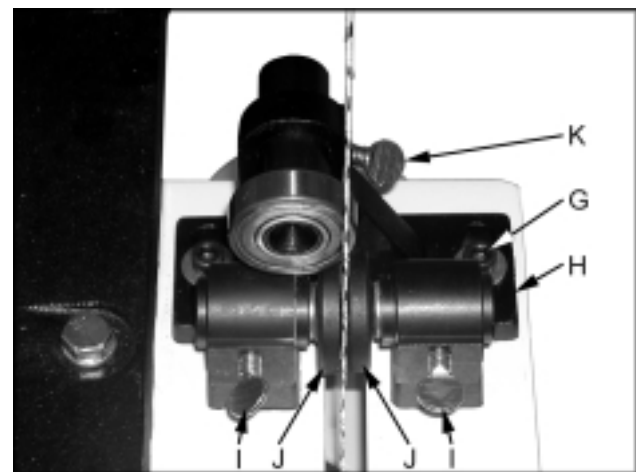

Fig. 4

Mounting the Table

1. Remove the table insert (A, Fig. 5) and table pin (B, Fig. 5).
2. Slide saw blade through slot in table where the table pin was located. Rotate the table 90 degrees so that the miter slot is parallel to the blade, and to the right of the blade when facing the bandsaw.
3. Line up the trunnions so that the bolts feed through the trunnion support bracket. Secure the table with two lock knobs (C, Fig. 6). Reinstall the table insert and table pin.

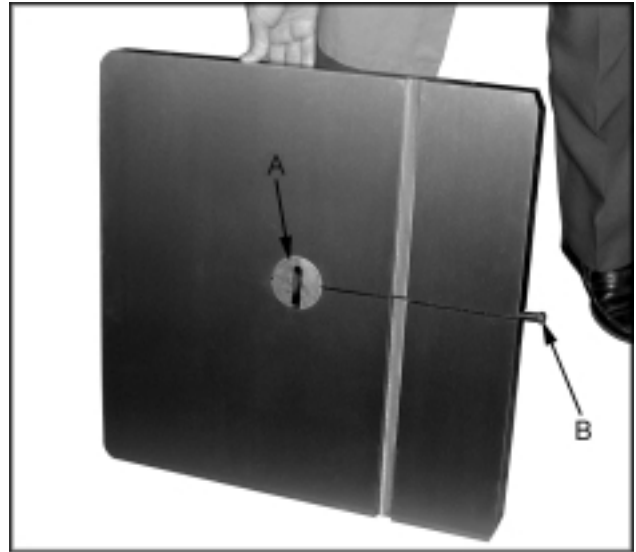

Fig. 5

Adjusting 90 Degree Table Stop

1. Blade tension and tracking must be properly adjusted prior to table stop setup.
2. Loosen lock knobs (C, Fig. 6) and tilt table until it rests against table stop bolt (D, Fig. 6). Tighten knobs.
3. Use a square (G, Fig. 7) placed on the table and against the blade to see if the table is 90 degrees to the blade.
4. If an adjustment is necessary, loosen the lock knobs. Tilt the table until it is square to the blade, and tighten the lock knobs.
5. Loosen lock nut (E, Fig. 6) and turn table stop bolt (D, Fig. 6) until it contacts the table. Tighten the nut (E, Fig. 6) to hold table stop in place. When tightening the nut hold the table stop bolt in place with a wrench to prevent movement.
6. If necessary, adjust pointer (F, Fig. 6) to zero.



Fig. 6



Fig. 7

Rail Assembly (optional accessory)

1. Attach the front rail (A, Fig. 8) to the cast iron table with two 1/4" x 5/8" hex cap bolts, two 1/4" lock washers, and two 1/4" flat washers. Bolts should be in approximately the center of the slot. Hand tighten only at this time.
2. Attach the rear rail (B, Fig. 8) to the table with two 1/4" x 5/8" hex cap bolts, two 1/4" lock washers, and two 1/4" flat washers. Bolts should be in approximately the center of the slot. Hand tighten only at this time.
3. Push the front, and rear rails up as far as they will go.
4. Tighten the four hex cap bolts holding the front, and rear rails to the table. **Do not** over tighten the bolts.
5. Attach the guide tube (C, Fig. 8) to the front rail with five 1/4" x 5/8" hex cap bolts, five 1/4" lock washers, and five 1/4" flat washers. Bolts should be in approximately the center of the slot.

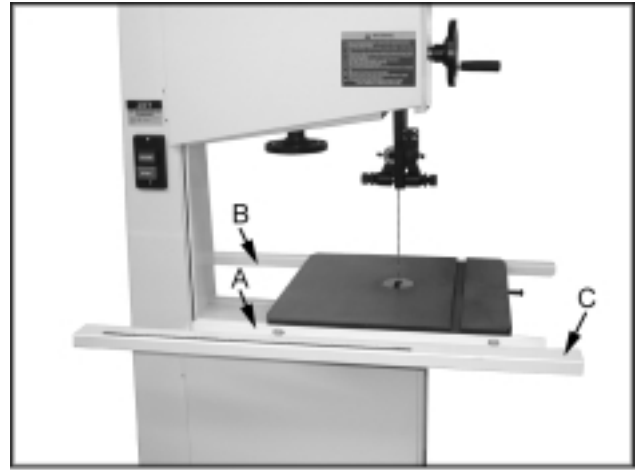

Fig. 8

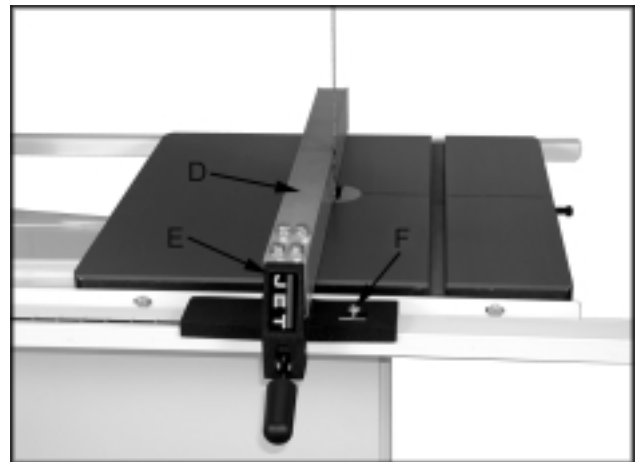

Fig. 9

Fence Assembly and Adjustment (optional accessory)

1. Attach the fence (D, Fig. 9) to the fence body (E, Fig. 9) with four 5/16" x 3/4" hex cap bolts, four 5/16" lock washers, and four 5/16" flat washers.
2. Thread a hex nut (G, Fig. 10) onto the pad's threaded stud (H, Fig. 10) and insert through the fence and rear hook (I, Fig. 10). Secure in place using a hex nut, lock washer and flat washer (J, Fig. 10).

Note: The hook should be adjusted so that it overlaps the rear rail by approximately 1/8".

3. Place fence assembly onto the guide tube. The rear hook should engage the rear rail.

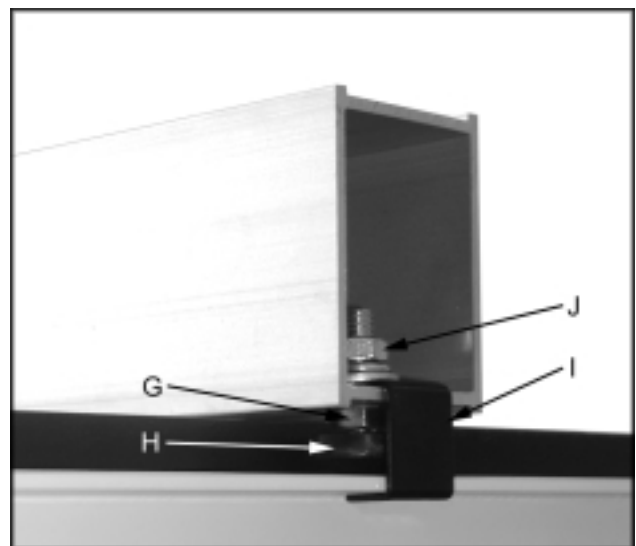

Fig. 10

4. Check the clearance between the table and the fence. The gap should be the same at the front of the table as it is at the rear. If the gap width is different, adjust the foot at the rear of the fence until the gap width is the same, Figure 11.

Note: You can also adjust the front rail, or rear rail up, or down to achieve the proper clearance.

5. With a square verify the fence face is perpendicular to the table top. If it is not the front rail will need to be adjusted parallel to the table top. This can be accomplished by measuring from the top of the table to the top of the front rail. The measurement should be the same at both ends of the table.
6. Move the fence assembly so that it aligns parallel to the blade, and lock the fence by pushing the lock handle down.
7. Loosen the four hex cap bolts that hold the fence, to the fence body, and align the fence to the blade. Tighten the four hex cap bolts.
8. Check to see that the pointer (C, Fig. 9) is aligned with the zero marking on the guide rail. If adjustment is necessary loosen the screw that holds the pointer in place and line up to the zero mark. Tighten the screw.

Note: If you cannot get the pointer lined up with the zero mark you can slide the guide tube and front rail left, or right to achieve the proper setting.

Resaw Guide (optional accessory)

For resawing attach the post (A, Fig. 12) to fence with the lock knob (B, Fig. 12). There is a slotted hole in the fence that will accommodate the resaw kit. Position the post so that it is centered with the front edge of the blade. The resaw guide will give you a taller, single point contact surface during resawing.

Miter Gauge (optional accessory)

1. Place the miter gauge in the table slot.
2. With a square verify the miter gauge face is square to the blade.
3. If the miter gauge is not square to the blade loosen the lock knob (C, Fig. 12) and adjust to the proper setting. Tighten the lock knob.

4. If the pointer is not at 90 degrees, loosen the screw (D, Fig. 12) holding the pointer and move the pointer to 90 degrees.

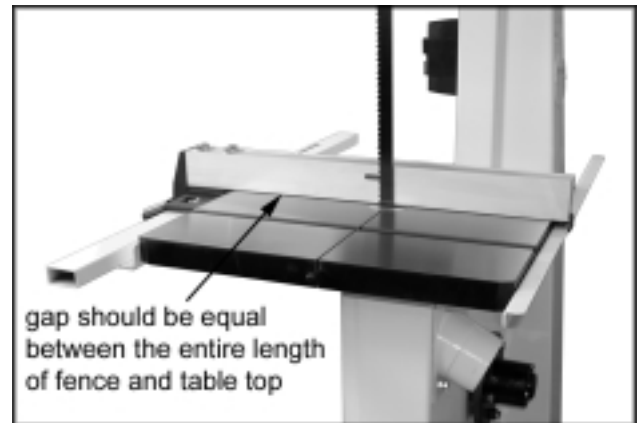

Fig. 11

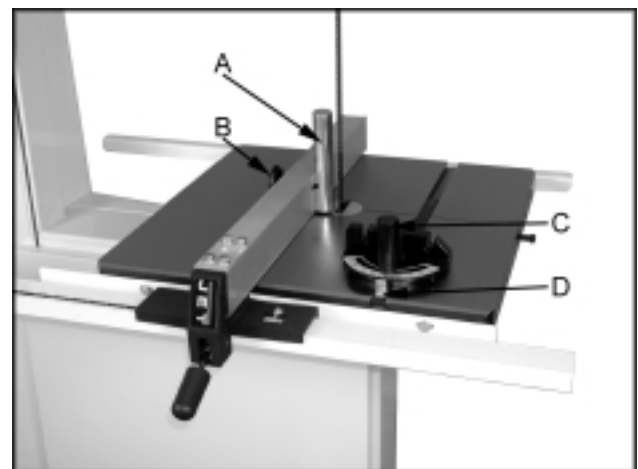

Fig. 12

Tilting the Table

1. **Disconnect the machine from the power source, unplug.**
2. Loosen the lock knobs (A, Fig. 13).
3. Tilt table up to 45 degrees to the right, or up to 10 degrees to the left.

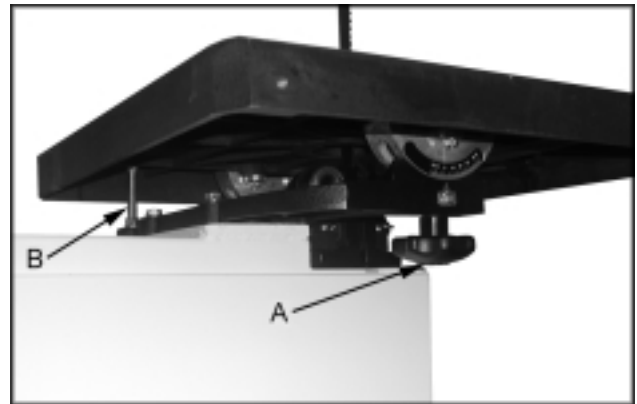

Fig. 13

4. Tighten the lock knobs.

Note: Table stop bolt (B, Fig. 13) must be removed to tilt table to the left.

Height Scale Adjustment

1. **Disconnect the machine from the power source, unplug.**
2. The upper blade guide should be set about 1/8" above the material to be cut.
3. Measure from the table top to the bottom of the blade guides, Figure 14.
4. Set the indicator to this measurement on the height scale. Grasp the end of the indicator (C, Fig. 15) between your finger, and thumb. Move the indicator into position.

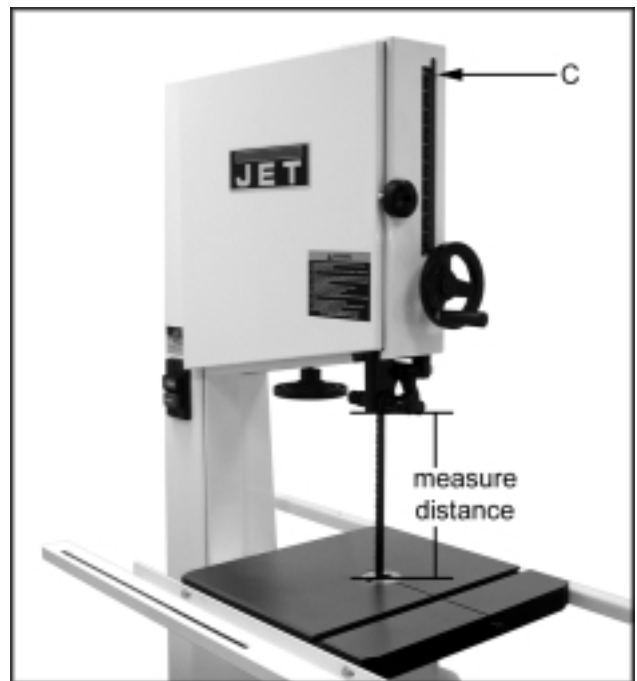

Fig. 14

Changing Blades



WARNING

Disconnect machine from the power source, unplug!

Blade teeth are sharp! Use care when handling the saw blade.

Failure to comply may cause serious injury!

1. Remove the table insert (A, Fig. 16), and table pin (B, Fig. 16).
2. Lower the upper blade guide assembly about half way by loosening the lock knob (F, Fig. 17) and turning the hand wheel (G, Fig. 17).
3. Loosen socket head cap screw (C, Fig. 16) and slide the blade guide assembly back as far as it will go.
4. Open both wheel covers (D, Fig. 16).
5. Loosen blade tension by turning blade tension hand wheel (E, Fig. 17) clockwise until it stops.

Note: You may want to wear leather work gloves while removing and handling the blade.

6. Carefully remove blade from upper and lower wheels. Remove the blade from between upper, and lower blade guides. Turn blade and direct through slot in table.
7. Make sure blade teeth point down toward table and guide the new blade through table slot. Place blade in upper, and lower blade guides.
8. Place blade in the middle of the upper and lower wheels.
9. Tension and track blade before operating saw. Find instructions for tensioning and tracking the blade on page 8 under "Adjusting Blade Tension" and "Adjusting Blade Tracking".
10. Replace table insert and table pin.

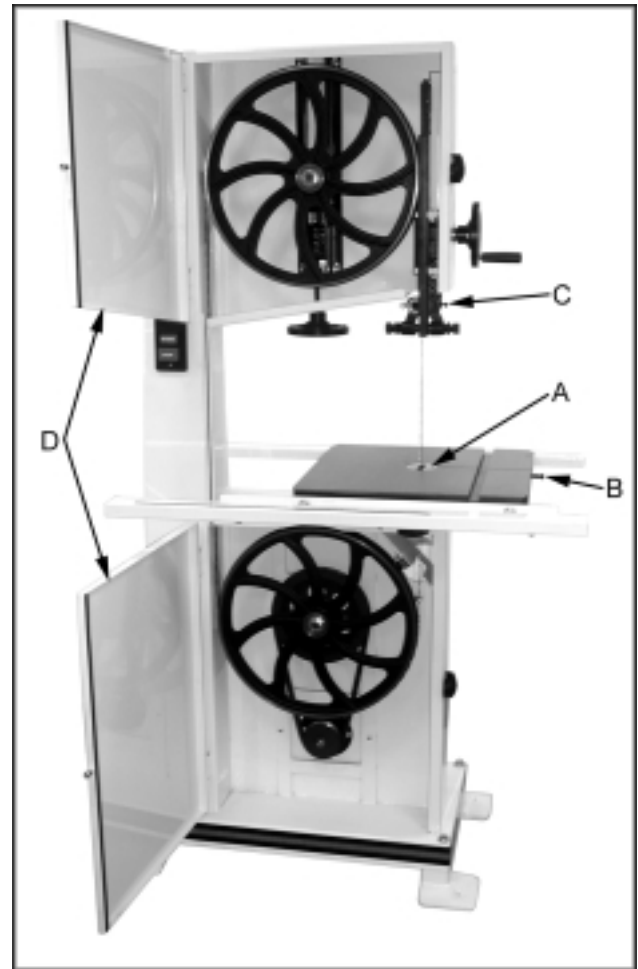

Fig. 16

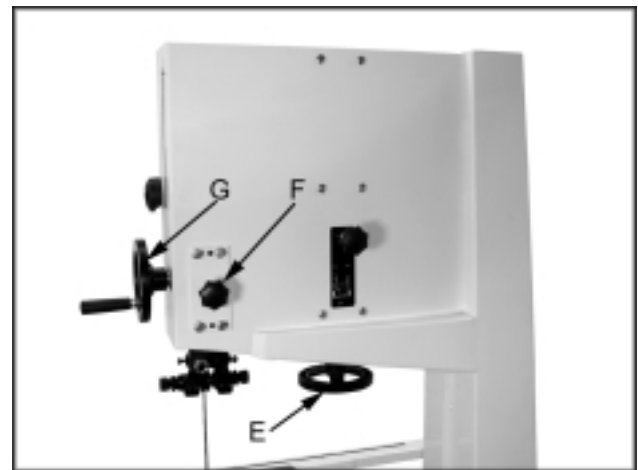

Fig. 17

Replacing V-Belt

1. **Disconnect the machine from the power source.**
2. Release blade tension by turning blade tension hand wheel clockwise.
3. Release belt tension by loosening the two hex cap bolts (A, Fig. 19). Raise the motor and tighten hex cap bolts to take the tension off the belt.
4. Open the lower wheel door and remove hex nut, and washer (B, Fig. 20).
5. Remove the wheel (C, Fig. 21). If the lower wheel does not come off easily you may need to use a pulley puller to remove the lower wheel.
6. Remove the old belt (D, Fig. 21) and replace the belt.
7. Reinstall the lower wheel and tighten the hex nut.
8. Loosen hex cap bolts and adjust the belt tension. See "Adjusting the Belt Tension."
9. Set the blade tension. See "Adjusting Blade Tension" on page 8.
10. Check the blade tracking. See "Adjusting Blade Tracking" on page 8.



Fig. 19

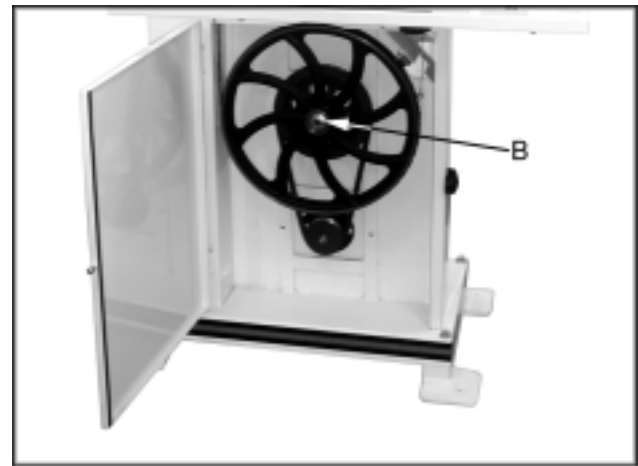

Fig. 20

Adjusting Belt Tension

The belt comes adjusted from the factory. If adjustment is needed:

1. **Disconnect the machine from the power source.**
2. Loosen hex cap bolts (A, Fig. 19).
3. Set the belt tension by lightly pressing down on the motor and tightening the hex cap bolts (A, Fig. 19).

Note: The weight of the motor should put enough tension on the belt. You just want to push down lightly to take up any slack.

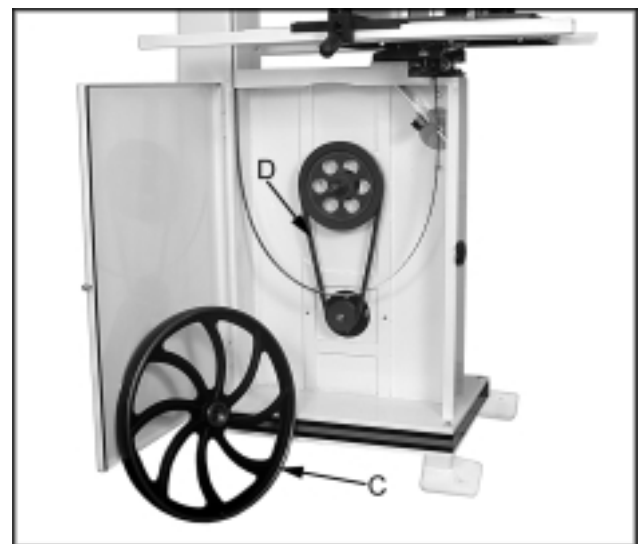

Fig. 21

Electrical Connections



WARNING!

All electrical connections must be done by a qualified electrician!
Failure to comply may result in loss of property and/or serious injury!

- JWBS-16 is rated at 1-1/2 HP, 1Ph, 115V/230V, prewired 115V.

The bandsaw comes with a 115V plug (A, Fig. 22). If you switch the motor to 230V a plug needs to be purchased for the bandsaw that matches the 230V outlet you intend to use.

Confirm power at the site is the same as the saw before making any electrical connections. Review the wiring diagram on page 30.

Review “Grounding Instructions” on page 4, “115 Volt Operation” also on page 4, and 230 Volt Operation on page 5.

Maintenance

Keep blade guides clean and free of build up.

Do not let saw dust build up in the upper and lower wheel housings. Vacuum out frequently.

Connect the bandsaw to a JET dust collection system.

Clean and grease the raising/lowering rack for the upper blade guides if it becomes difficult to raise, or lower.

Clean, and oil the tensioning mechanism if it becomes difficult to adjust.

Vacuum out the motor fan cover.

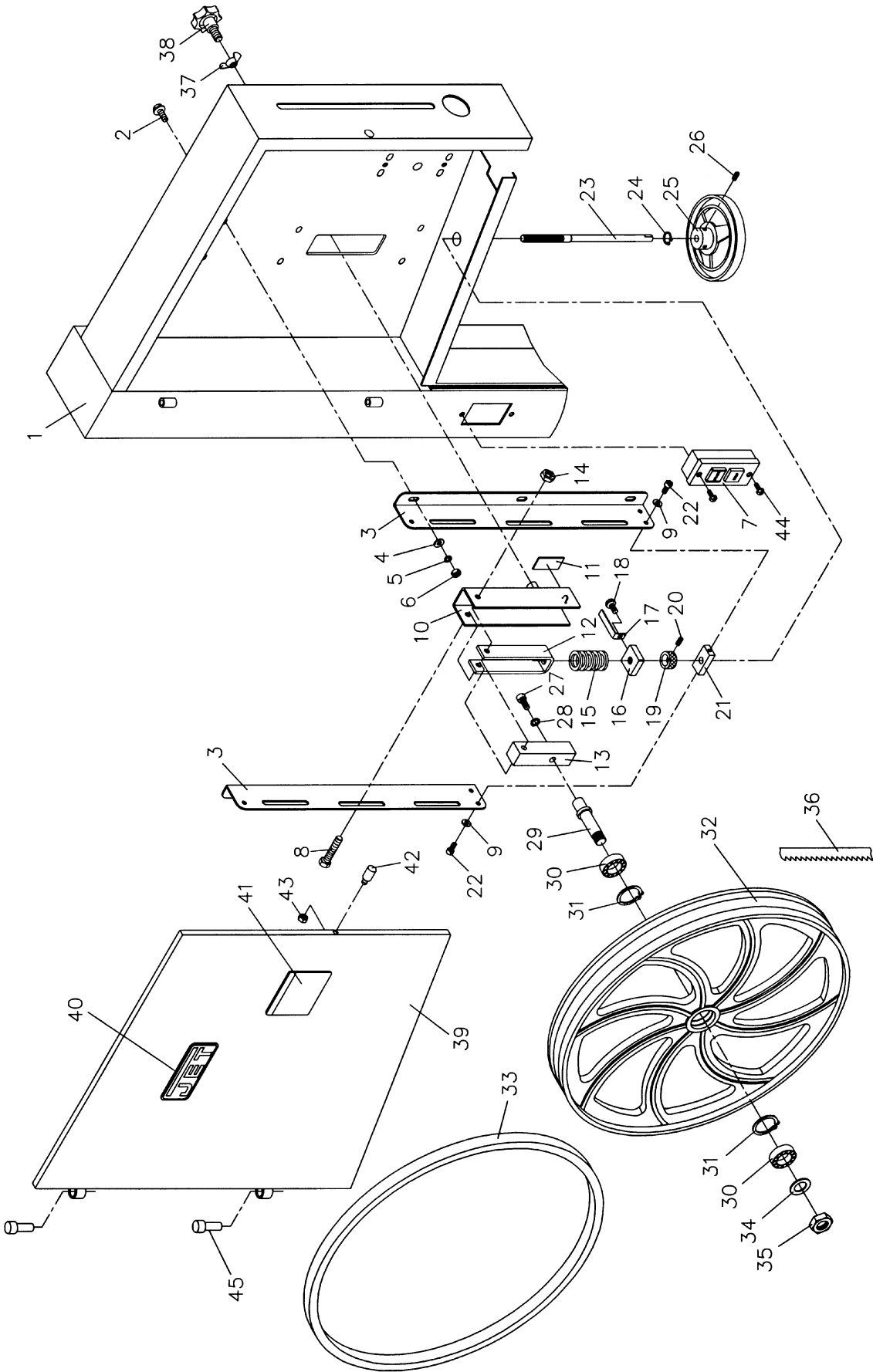

Fig. 22

Troubleshooting

Trouble	Possible Cause	Solution
Saw stops or will not start	<ol style="list-style-type: none"> 1. Saw unplugged 2. Fuse blown or circuit breaker tripped 3. Cord damaged 	<ol style="list-style-type: none"> 1. Check plug connections 2. Replace fuse or reset circuit breaker 3. Replace cord
Does not make accurate 45° or 90° cuts	<ol style="list-style-type: none"> 1. Stop not adjusted correctly 2. Angle pointer not set accurately 3. Miter gauge out of adjustment 	<ol style="list-style-type: none"> 1. Check blade with square and adjust stop 2. Check blade with square and adjust pointer 3. Adjust miter gauge
Blade wanders during cut	<ol style="list-style-type: none"> 1. Fence not aligned with blade 2. Warped wood 3. Excessive feed rate 4. Incorrect blade for cut 5. Blade tension not set properly 6. Guides not set properly 	<ol style="list-style-type: none"> 1. Check and adjust fence 2. Select another piece of wood 3. Reduce feed rate 4. Change blade to correct type 5. Set blade tension according to blade size 6. Review guide adjustment on pages 8
Saw makes unsatisfactory cuts	<ol style="list-style-type: none"> 1. Dull blade 2. Blade mounted wrong 3. Gum or pitch on blade 4. Incorrect blade for cut 5. Gum or pitch on table 	<ol style="list-style-type: none"> 1. Replace blade 2. Teeth should point down 3. Remove blade and clean 4. Change blade to correct type 5. Clean table
Blade does not come up to speed	<ol style="list-style-type: none"> 1. Extension cord too light or too long 2. Low shop voltage 	<ol style="list-style-type: none"> 1. Replace with adequate size and length cord 2. Contact your local electric company
Saw vibrates excessively	<ol style="list-style-type: none"> 1. Base on uneven floor 2. Bad V-belt 3. Motor mount is loose 4. Loose hardware 	<ol style="list-style-type: none"> 1. Reposition on flat, level surface 2. Replace V-belt 3. Tighten motor mount hardware 4. Tighten hardware

Upper Wheel Assembly



Upper Wheel Assembly

Index No.	Part No.	Description	Size	Qty.
1	JWBS16-101	Saw Body		1
2	TS-0152011	Carriage Bolt	5/16-18 x 1"	6
3	JWBS18-103	Upper Wheel Bracket		2
4	TS-0680031	Flat Washer	5/16	6
5	TS-0720081	Lock Washer	5/16	6
6	TS-0561021	Hex Nut	5/16-18	6
7	994542	Switch		1
8	JWBS18-108	Hex Cap Bolt	M8 x 65	1
9	TS-0680021	Flat Washer	1/4	4
10	JWBS18-110	Sliding Bracket		1
11	JWBS18-111	Blade Tension Indicator		1
12	JWBS18-112	Adjustment Bracket		1
13	JWBS18-113	Shaft Bracket		1
14	TS-1540061	Hex Nut	M8	1
15	JWBS18-115	Spring		1
16	JWBS18-116	Square Nut		1
17	JWBS18-117	Pointer		1
18	JWBS18-118	Screw	M5 x 8	1
19	JWBS18-119	Set Block		1
20	TS-0267021	Set Screw	1/4-20 x 1/4	1
21	JWBS18-121	Bracket		1
22	TS-0050021	Hex Cap Bolt	1/4-20 x 5/8	4
23	JWBS16-123	Blade Adjusting Screw		1
24	JWBS18-124	E-Ring	E-9	1
25	JWBS18-125	Hand Wheel		1
26	TS-0267041	Socket Set Screw	1/4-20 x 3/8	2
27	TS-0209021	Socket Head Cap Screw	3/8-16 x 5/8	1
28	TS-0720091	Lock Washer	3/8	1
29	JWBS18-129	Upper Wheel Shaft		1
30	BB-6203ZZ	Ball Bearing	6203	2
31	JWBS18-131	Retaining Ring	R40	2
32	JWBS16-132	Upper Wheel		1
33	JWBS16-133	Tire		1
34	JWBS18-134	Flat Washer		1
35	JWBS18-135	Hex Nut	5/8-18UNF L.H.	1
36	709181	Silicon Steel Blade 123" x 3/16" x 0.025" 10 Raker		
	709182	Silicon Steel Blade 123" x 3/8" x 0.025" 6 Hook		
	709183	Silicon Steel Blade 123" x 3/8" x 0.025" 10 Raker		
	709184	Silicon Steel Blade 123" x 3/8" x 0.025" 14 Raker		
	709185	Silicon Steel Blade 123" x 1/2" x 0.025" 4 Hook		
	709186	Silicon Steel Blade 123" x 1/2" x 0.025" 6 Hook		
	709277	Blade 123" x 1/8" x 0.025" 14 Raker		
	709278	Blade 123" x 3/16" x 0.025" 4 Skip		
	709279	Blade 123" x 1/4" x 0.025" 6 Hook		
	709280	Blade 123" x 1/4" x 0.025" 14 Raker		
	709281	Blade 123" x 3/8" x 0.025" 4 Hook		
	709282	Premium Blade 123" x 3/8" x 0.025" 14 Raker		
	709283	Premium Blade 123" x 1/2" x 0.025" 3 Hook		
	709284	Premium Blade 123" x 1/2" x 0.025" 6 Hook		
	709285	Premium Blade 123" x 3/4" x 0.032" 3 Hook		
	709286	Premium Blade 123" x 3/4" x 0.032" 10 Raker		
	709287	Premium Blade 123" x 1" x 0.035" 6 Hook		
	709288	Premium Blade 123" x 1" x 0.035" 10 Hook		
	709576	Carbide Embedded Blade 123" x 1/4" x 0.025" 6 Skip		

Index No.	Part No.	Description	Size	Qty.
.....	709577	Carbide Embedded Blade 123" x 3/8" x 0.025" 4 Skip		
.....	709578	Carbide Embedded Blade 123" x 1/2" x 0.025" 3 Hook		
.....	709579	Carbide Embedded Blade 123" x 5/8" x 0.025" 3 Hook		
37	TS-0590061	Wing Nut	5/16	1
38	JWBS18-138	Lock Knob	5/16	1
39	JWBS16-139	Upper Front Door		1
40	JWBS18-140	JET Plaque		1
41	JWBS18-141	Warning Label		1
42	JWBS18-142	Bolt		1
43	TS-0561011	Hex Nut	1/4-20	1
44	JWBS18-144	Screw	3/16 x 3/4	2
45	JWBS18-39A	Door Hinge Pin		2

Lower Wheel and Motor Assembly

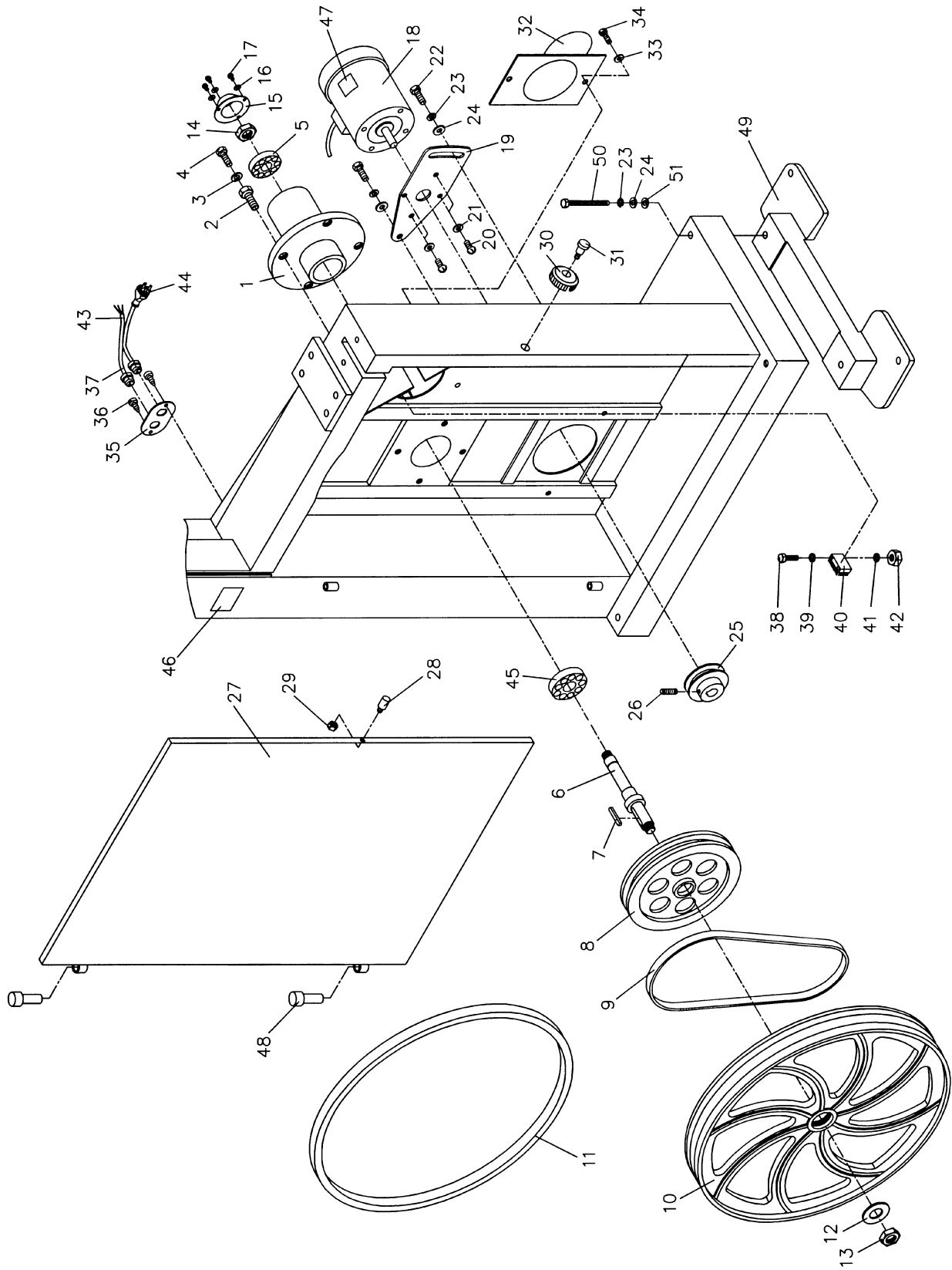

Lower Wheel and Motor Assembly

Index No.	Part No.	Description	Size	Qty.
1	JWBS18-201N	Bearing Base		1
2	JWBS20-62	Adjusting Bolt		4
3	TS-0720091	Lock Washer	3/8	4
4	TS-0060081	Hex Cap Bolt	3/8 x 1-3/4	4
5	BB-6204ZZ	Ball Bearing	6204	1
6	JWBS18-206N	Spindle		1
7	JWBS18-207	Key	7 x 7 x 40	1
8	JWBS18-208	Spindle Pulley		1
9	VB-B40	V-Belt	B-40	1
10	JWBS16-210	Lower Wheel		1
11	JWBS16-133	Tire		1
12	TS-0680081	Flat Washer	5/8	1
13	JWBS18-135	Hex Nut	5/8-18UNF L.H.	1
14	JWBS18-214	Hex Nut	5/8-18UNF R.H.	1
15	JWBS18-215	Bearing Cover		1
16	JWBS18-216	Lock Washer	3/16	3
17	JWBS18-217	Screw	3/16 x 3/8	3
18	JWBS18-218	Motor		1
	JWBS16-SC	Starting Capacitor (not shown)	200 MFD, 125 VAC	1
	JWBS16-RC	Running Capacitor (not shown)	16 uF, 250 VAC	1
	JWBS16-SCC	Starting Capacitor Cover (not shown)		1
	JWBS16-RCC	Running Capacitor Cover (not shown)		1
	JWBS18-FAN	Fan (not shown)		1
	JWBS18-CS	Centrifugal Switch (not shown)		1
	JWBS16-MFC	Motor Fan Cover (not shown)		1
19	JWBS18-219	Motor Bracket		1
20	TS-0081031	Hex Cap Bolt	5/16 x 3/4	4
21	TS-0680031	Flat Washer	5/16	4
22	TS-0060051	Hex Cap Bolt	3/8-16 x 1	2
23	TS-0720091	Lock Washer	3/8	6
24	TS-0680041	Flat Washer	3/8	6
25	JWBS16-225	Motor Pulley		1
26	TS-0267021	Socket Set Screw	1/4-20 x 3/8	2
27	JWBS16-227W	Lower Front Door		1
28	JWBS18-142	Bolt		1
29	TS-0561011	Hex Nut	1/4-20	1
30	JWBS20-2	Lock Knob		1
31	JWBS20-3	Screw	1/4 x 3/4	1
32	JWBS20-8W	White Dust Chute		1
33	TS-0680031	Flat Washer	5/16	2
34	TS-0051051	Hex Cap Bolt	5/16-18 x 1	2
35	JWBS18-235	Plate		1
36	JWBS18-236	Screw	3/16 x 1/2	2
37	JWBS18-237	Strain Relief Bushing		2
38	JWBS18-238	Screw	3/16 x 1-1/2	2
39	TS-0680011	Flat Washer	3/16	2
40	JWBS18-240	Brush		1
41	JWBS18-241	Lock Washer	3/16	2
42	JWBS18-242	Hex Nut	3/16	2
43	JWBS18-243	Motor Cord		1
44	JWBS18-244	Power Cord		1
45	BB-6205ZZ	Ball Bearing	6205	1
46	JWBS16-246	I.D. Label		1
47	JWBS16-247	Motor Label		1

Index No.	Part No.	Description	Size	Qty.
48	JWBS18-39A	Door Hinge Pin		2
49	JWBS16-249	Cast Foot		2
50	TS-0060171	Hex Cap Bolt	3/8-16 x 4	4
51	JWBS16-251	Flat Washer (plastic)	3/8	4

Blade Guides Assembly

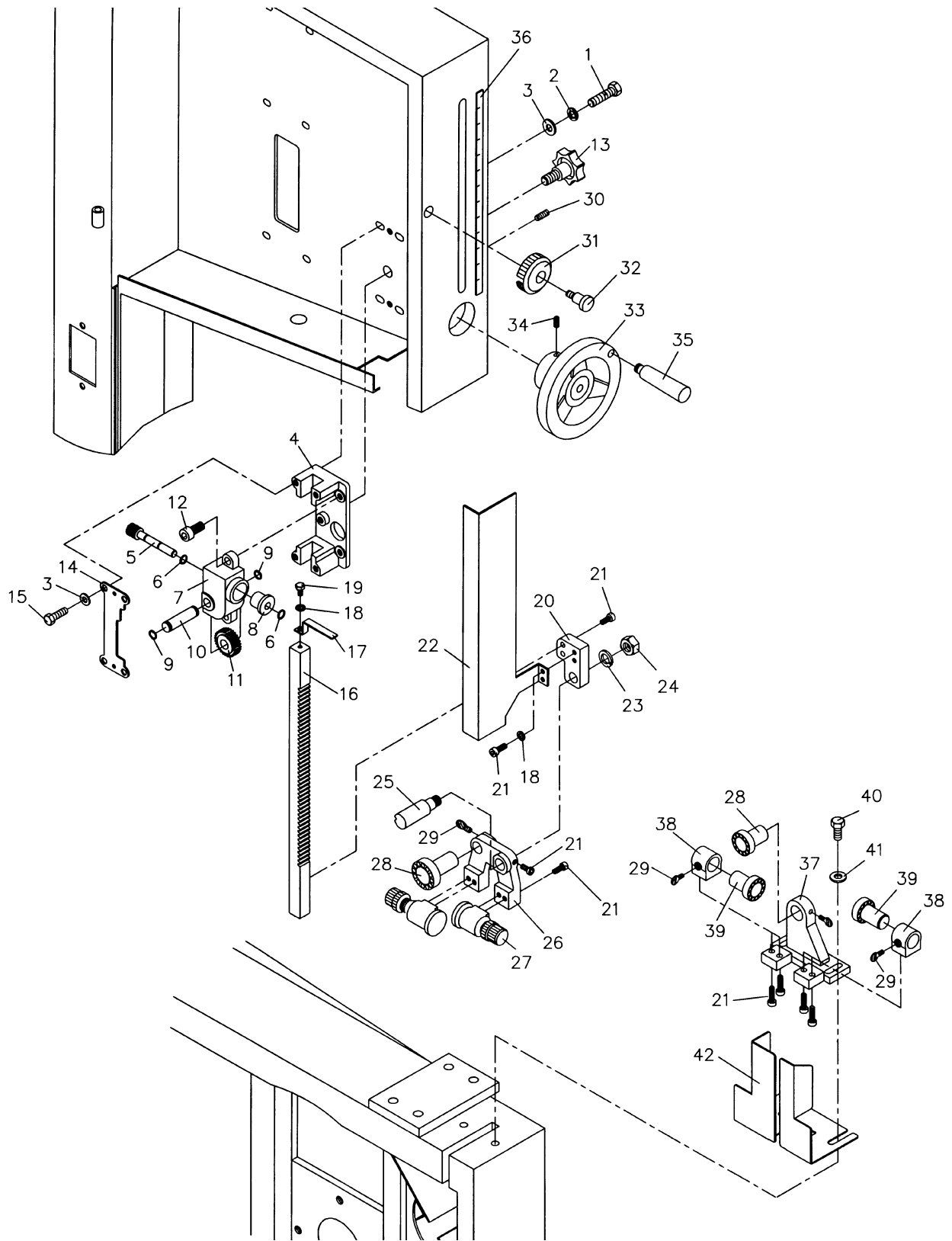

Blade Guides Assembly

Index No.	Part No.	Description	Size	Qty.
1	TS-0051051	Hex Cap Bolt	5/16 x 1	4
2	TS-0720081	Lock Washer	5/16	4
3	TS-0680031	Flat Washer	5/16	8
4	JWBS18-304	Guide Bar Bracket		1
5	JWBS18-305	Worm		1
6	JWBS18-306	E-Ring	E-8	2
7	JWBS18-307	Gear Base		1
8	JWBS18-308	Bushing		1
9	JWBS18-309	C-Ring	S-12	2
10	JWBS18-310	Shaft		1
11	JWBS18-311	Gear		1
12	TS-0208071	Socket Head Cap Screw	5/16 x 1-1/4	2
13	JWBS18-313	Lock Knob	5/16	1
14	JWBS18-314	Plate		1
15	TS-0051011	Hex Cap Bolt	5/16 x 1/2	4
16	JWBS18-316	Guide Bar		1
17	JWBS18-317	Pointer		1
18	TS-0720071	Lock Washer	1/4	3
19	TS-0050011	Hex Cap Bolt	1/4 x 1/2	1
20	JWBS18-320	Guide Bracket		1
21	TS-0207021	Socket Head Cap Screw	1/4 x 1/2	13
22	JWBS18-322	Blade Guard		1
23	TS-0720111	Lock Washer	1/2	1
24	TS-0561051	Hex Nut	1/2-13	1
25	JWBS20-110	Locking Shaft		1
26	JWBS20-115	Upper Guide Bracket		1
27	JWBS20-114	Guide Wheel Assembly		2
28	JWBS20-113	Blade Support Shaft w/ Bearing		2
29	JWBS18-329	Thumb Screw	1/4 x 1/2	4
30	TS-0270031	Socket Set Screw	5/16 x 3/8	2
31	JWBS20-2	Lock Knob		1
32	JWBS20-3	Screw	1/4 x 3/4	1
33	JWBS18-333	Hand Wheel		1
34	TS-0267041	Socket Set Screw	1/4 x 3/8	1
35	JWBS20-103A	Handle		1
36	JWBS18-336	Cutting Height Scale		1
37	JWBS20-120	Lower Guide Bracket		1
38	JWBS18-338	Lower Guide Wheel Housing		2
39	JWBS18-339	Lower Guide Wheel Assembly		2
40	TS-0207031	Socket Head Cap Screw	1/4 x 5/8	2
41	TS-0680021	Flat Washer	1/4	2
42	JWBS18-342	Lower Blade Guard		1

Table Assembly

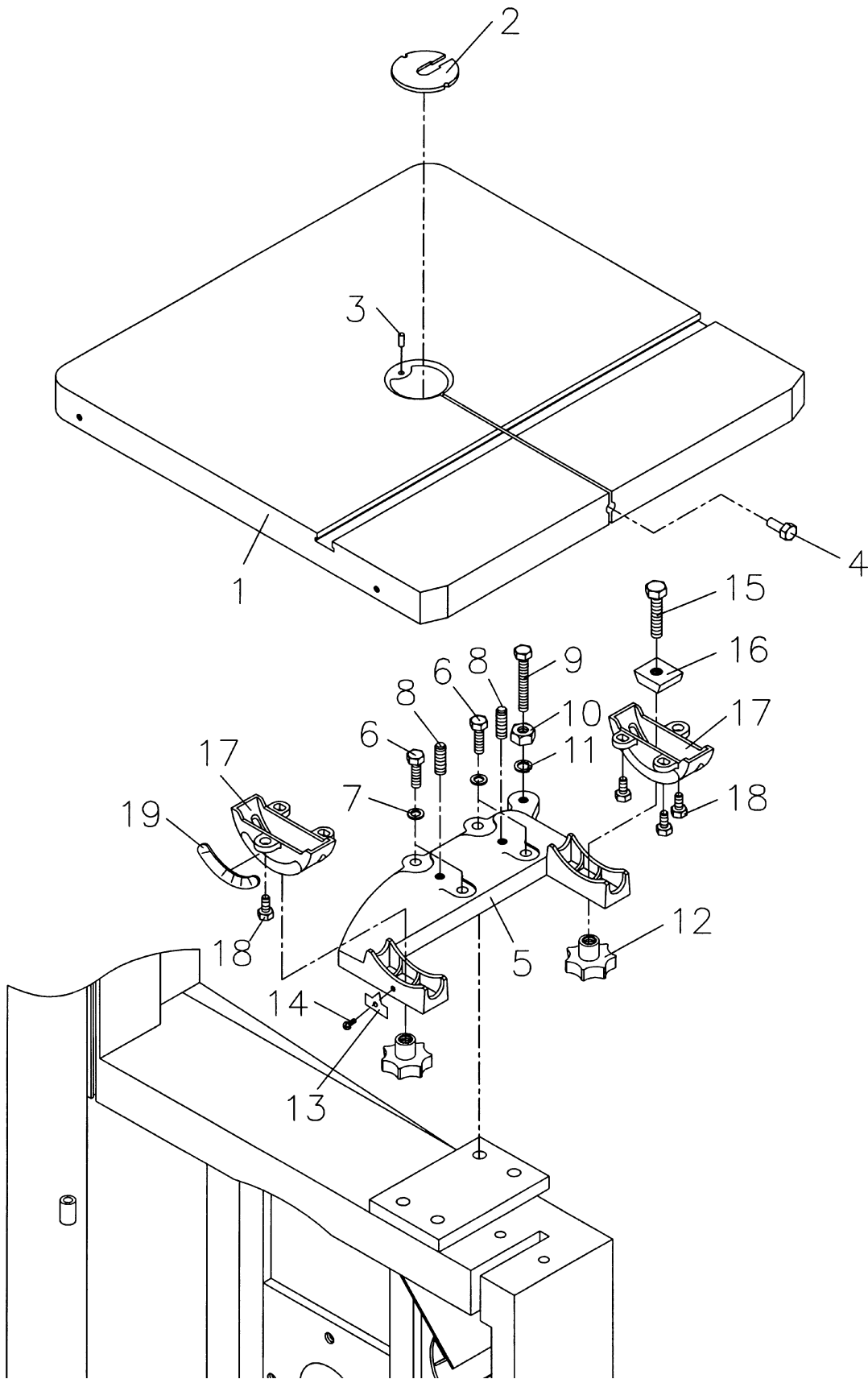
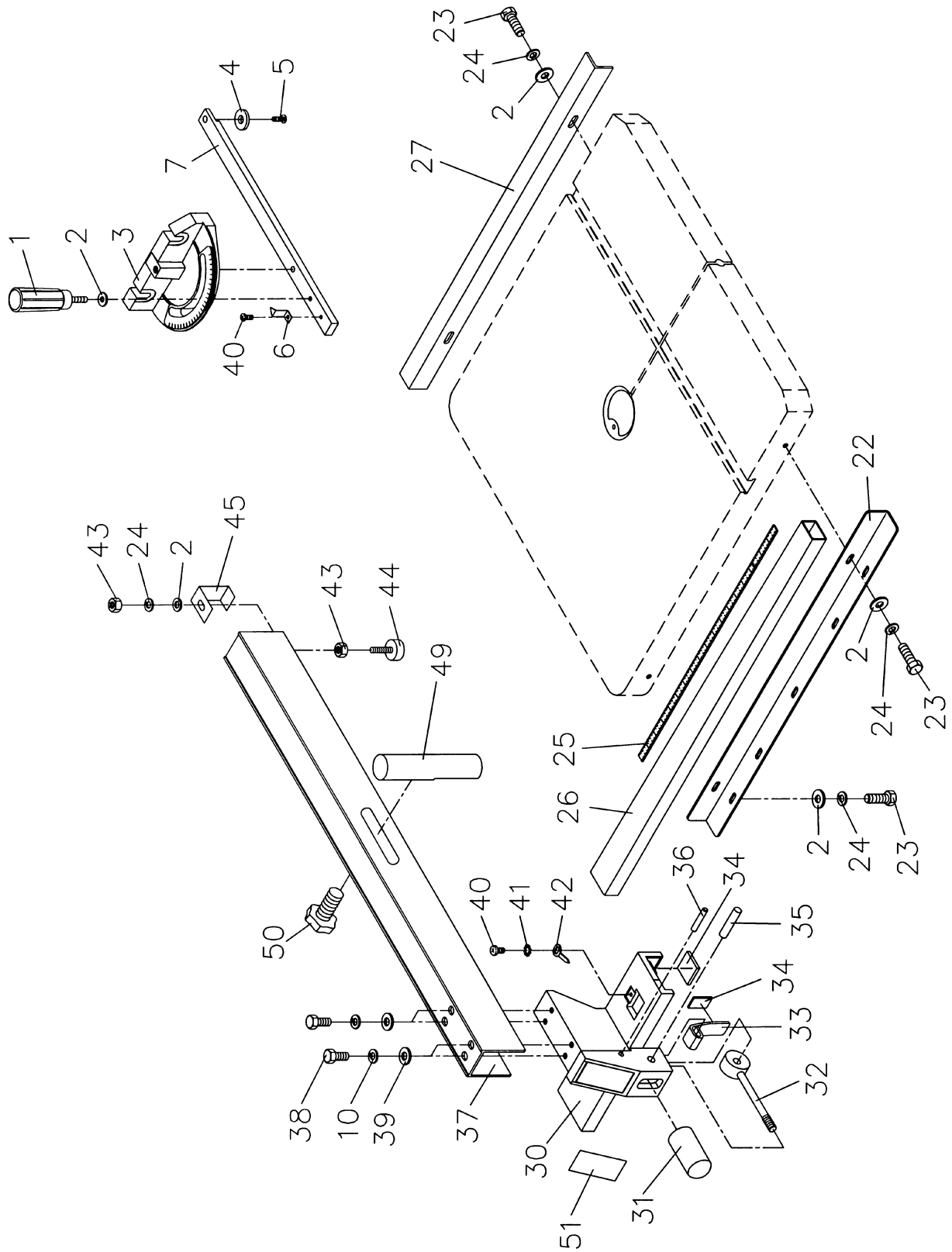

Table Assembly

Index No.	Part No.	Description	Size	Qty.
1	JWBS16-401	Table		1
2	JWBS20-144	Table Insert		1
3	JWBS20-145	Roll Pin	3 x 10	1
4	JWBS18-448	Table Pin		1
5	JWBS18-408N	Trunnion Support Bracket		1
6	TS-0051071	Hex Cap Bolt	5/16 x 1-1/2	4
7	TS-0720081	Lock Washer	5/16	4
8	TS-0270061	Set Screw	5/16 x 5/8	2
9	TS-0060111	Hex Cap Bolt	3/8 x 2-1/2	1
10	TS-0561031	Hex Nut	3/8	1
11	TS-0720091	Lock Washer	3/8	1
12	JWBS18-415	Lock Knob		2
13	JWBS18-446	Pointer		1
14	JWBS18-447	Screw	M5 x 8	1
15	TS-1491081	Hex Cap Bolt	M10 x 50	2
16	JWBS18-417	Trunnion Clamp Shoe		2
17	JWBS18-416	Trunnion		2
18	TS-1482021	Hex Cap Bolt	M6 x 12	6
19	JWBS18-420	Scale		1

Fence & Miter Assembly (optional accessory)



Fence & Miter Assembly (optional accessory)

Index No.	Part No.	Description	Size	Qty.
1	JWBS18-401	Lock Knob		1
2	TS-0680021	Flat Washer	1/4	11
3	JWBS18-403	Miter Gauge Body		1
4	200156	Guide Disc		1
5	JWBS18-405	Pan Head Screw	M6 x 8	1
6	JWBS18-406	Pointer		1
7	JWBS18-407	Guide Bar		1
10	TS-0720081	Lock Washer	5/16	4
22	JWBS18-422W	Front Rail		1
23	TS-0050021	Hex Cap Bolt	1/4-20 x 5/8	9
24	TS-0720071	Lock Washer	1/4	10
25	JWBS18-425	Scale		1
26	JWBS18-426W	Guide Rail		1
27	JWBS18-427W	Rear Rail		1
30	JWBS18-430	Fence Body		1
31	JWBS18-431	Knob		1
32	JWBS18-432	Lock Handle		1
33	JWBS18-433W	Lock Plate		1
34	JWBS18-434	Pad		5
35	JWBS18-435	Pin		1
36	JWBS18-436	Pin		1
37	JWBS16-437	Fence		1
38	TS-0081031	Hex Cap Bolt	5/16 x 3/4	4
39	TS-0680031	Flat Washer	5/16	4
40	JWBS18-440	Screw	3/16 x 1/4	2
41	JWBS18-441	Star Washer	3/16	1
42	JWBS18-442	Pointer		1
43	TS-0561011	Hex Nut	1/4-20	2
44	JWBS18-444	Sliding Pad		1
45	JWBS18-445	Rear Hook		1
49	JWBS18-449	Resaw Post		1
50	JWBS18-450	Knob		1
51	JWBS18-451	JET Fence Label		1
	JWBS18-MGCP	Miter Gauge Assembly		1
	JWBS16-FCP	Fence Assembly Complete		1

Wiring Diagram

